



## Steel Dock Boards

*Fully welded steel dock boards provide a safe ramp for powered vehicle application. Selecting the proper Bluff product for your application will improve product life, safety, and loading efficiency.*

### STEEL DOCK BOARD (T)

- All-welded steel construction
- Capacities from 15,000 to 40,000 pounds
- Two four-hole pin pockets placed on each edge for flexible positioning
- Fold-down lifting loops
- Double-bend design

This heavy-duty steel dock board is held in position using two 1" stress-proof steel pins. When properly placed in the side pocket location holes, these pins hold the dock board firmly in place guarding against slippage. Simply select the proper pin hole location for use with conventional, refrigerated, or container trailers, or for below dock conditions. Widths from 60" to 96".



### STEEL DOCK BOARD (TFL)

Same basic design as the "T" dock board, but uses locking legs in lieu of steel pins.

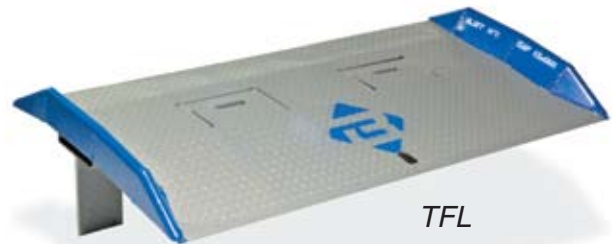

### STEEL DOCK BOARD (TNB)

Single-bend design utilizes the lifting chain and full width locking legs.

TFL and TNB designs are not recommended for below dock loading.

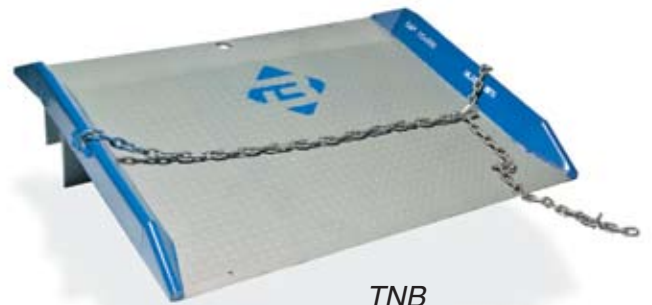

Manufactured and tested in compliance with ANSI Standard MH30.2

***SERVICE YOU CAN STAND ON***

(800) 433-2212 • [www.bluffmanufacturing.com](http://www.bluffmanufacturing.com) • Fax 817-293-7570  
1400 Everman Parkway • Suite 156 • Fort Worth, TX 76140

## STEEL DOCK BOARDS MODEL T

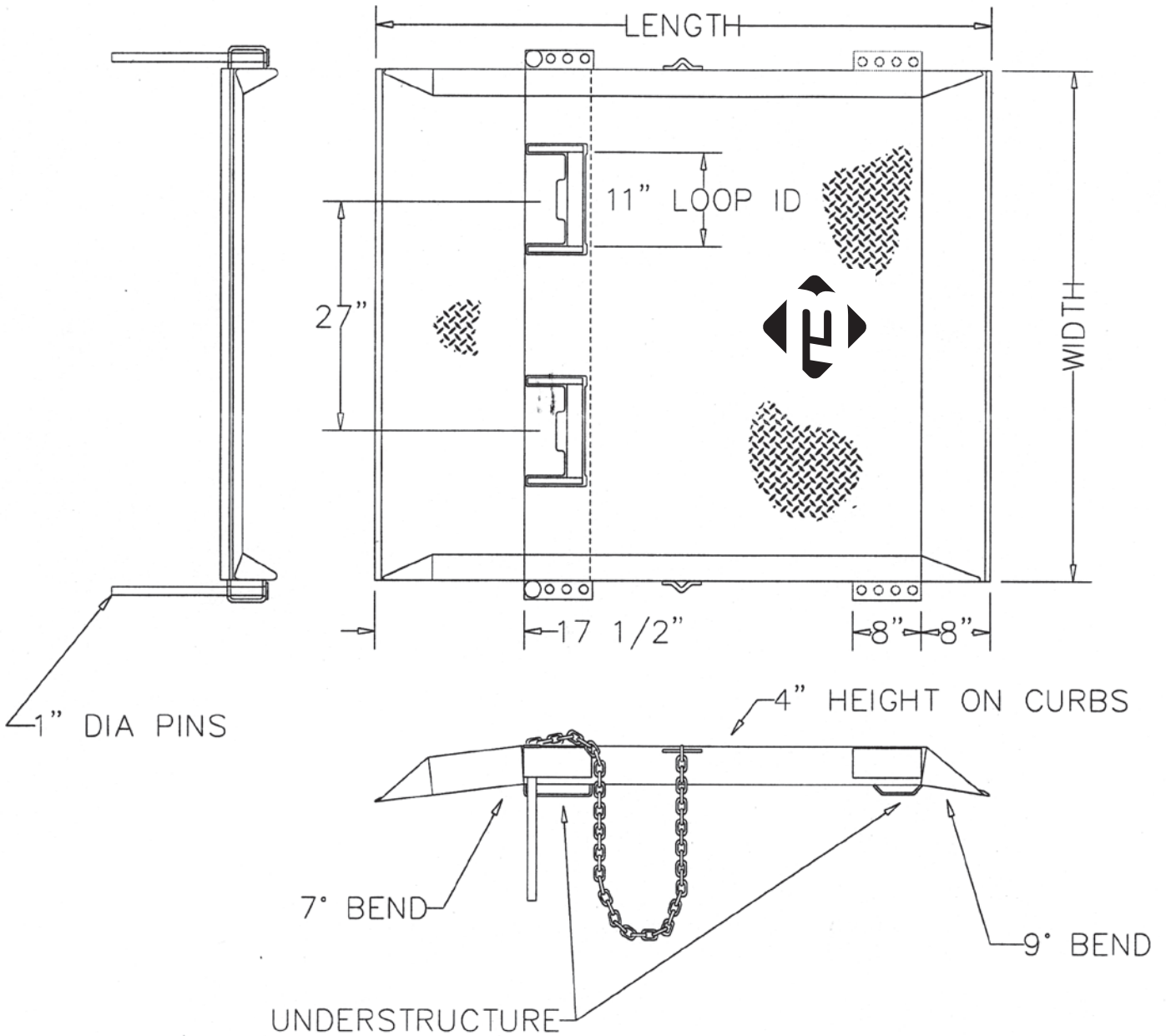

**15T6072**

- LENGTH
- WIDTH
- MODEL
- 15,000 CAPACITY

BOARD LENGTH

48"–60"

66"–72"

78"–84"

90"–96"

PIN LENGTH

20"

24"

30"

36"

**FOR INFORMATION ON TFL OR TNB MODELS, CONTACT BLUFF CUSTOMER SERVICE.**