



Date: _____ Phone: _____

Company: _____

Name: _____

Dock Board Worksheet

1. What is the lifting capacity of the forklift? _____ lbs.
2. Is the forklift: 4-wheel or 3-wheel
3. Is the board used more than one shift a day? Yes No
4. What is the product that is traveling over the board? _____
5. What type of trailers will be serviced at the dock? _____
6. What is the dock height? (D) _____ inches
7. What is the highest trailer serviced? (T) _____ inches
8. What is the lowest trailer serviced? _____ inches
9. What is the maximum difference in height? (H) _____ inches
(see Height Differential calculator at the bottom of this sheet to determine H)
10. What type of equipment is used? Pallet Trucks or Hand Trucks Gas/Propane Forklifts
 Electric Forklifts Other _____
11. What is the width of the forklift? _____ inches. *(The board should be 12" wider than the equipment used.)*
12. Is the trailer parked away from the dock? Yes No
13. Other conditions: _____

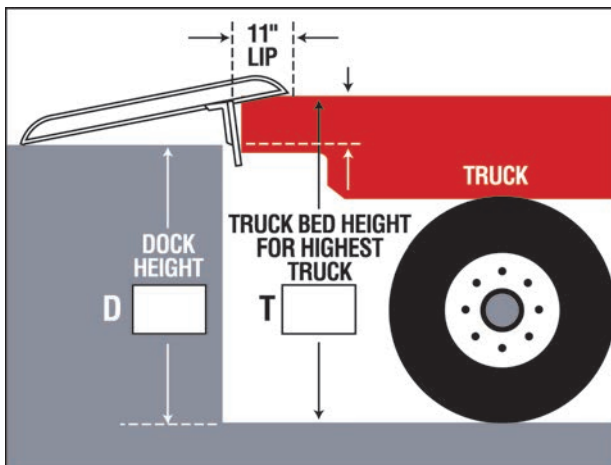

HEIGHT DIFFERENTIAL

Highest Truck Height (T)

We recommend using 55" for the (T) unless your customer says otherwise, since 55" is the maximum height of most trailers. On refrigerated or container trailers use 59"

T = inches

- D = inches

H = inches

Dock Height (D)

(You must measure this)

Height Differential (Maximum) (H)
(H) is equal to (T) minus (D).